



PowerSpout - Getting started



Low Head (LH)



Medium Head Turgo (TRG)



High Head Pelton (PLT)



CONTENTS

1. What is a PowerSpout? 3

 1.1. What is Head? 3

 1.2. What is Flow? 4

 1.3. Which PowerSpout should I choose? 5

 1.4. What if I actually need a pump rather than a power source? 5

 1.5. Can I run a turbine off a pump to make power? 6

 1.6. Can I run a turbine off my pool pump to reduce my power bill? 6

 1.7. Why not pump water up a hill, and run a turbine as it comes down? 6

 1.8. Can I use water from my tap? It comes out at very high pressure 6

 1.9. When it rains there is a good flow from my roof. Could that run a PowerSpout? 6

 1.10. Can I use a large river to power my home? 6

 1.11. Who should actually consider buying a PowerSpout? 7

2. What can PowerSpout do for me? 7

 2.1. How much electricity will a PowerSpout provide? 7

3. What else will I need? 8

 3.1. Do I need to build a dam? 8

 3.2. How big does the pipe need to be? 9

 3.3. Can I run my house directly from the PowerSpout? 9

 3.4. Can I use Powerspout parts and build my own turbine to my own design? 9

4. How much will it cost? 10

5. How do I buy one? 10

 5.1. What site data do I need and how do I use it? 11

 5.2. Demand side data 11

6. Placing the order 11

 6.1. Important notes 12

7. Product range 13

8. Data required for PowerSpout manufacture 14



PLT in sound proof enclosure

1. What is a PowerSpout?

There are several PowerSpout products to choose from. They all use the power of water to provide electricity, or to pump water. If you have access to a source of water that descends in height across your property then you may be able to use it to charge batteries, reduce your electricity bills or to pump water. But first you need to learn a bit more about how it works and whether it can work for you. If the technical stuff gets you down there is a worldwide network of dealers available to help you find out the possibilities. All global dealers are listed on our website at <https://www.powerspout.com/collections/find-a-dealer-1> "No other manufacturer of pico equipment has such a well-considered product range or spares/service network."

Throughout this document we make reference to the many other PowerSpout titles that you can download and study as PDF files. There is a master document [PowerSpout Document Index Links](#). Take the time to watch some videos, read case studies and learn from the manuals.

1.1. What is Head?

As soon as you start to read about hydro, you will read the word "Head" because it's one of the big players in the game. Head simply means pressure and the easiest way to measure it is using a gauge as shown on the right. But first you would need to get a pipe full of water from your intake to your turbine site. During the initial survey you will more likely have to estimate the head based on measuring the vertical drop between intake and turbine.



Pressure of water depends entirely on this difference in height. (The amount of water behind any dam you might build at the top does not make any difference to this by the way.)

You can estimate the head from map contours, or using an accurate altimeter (or GPS) or by working your way up the slope with a level sight and counting how many "eye level heights" it takes you to get from turbine site to intake water level.

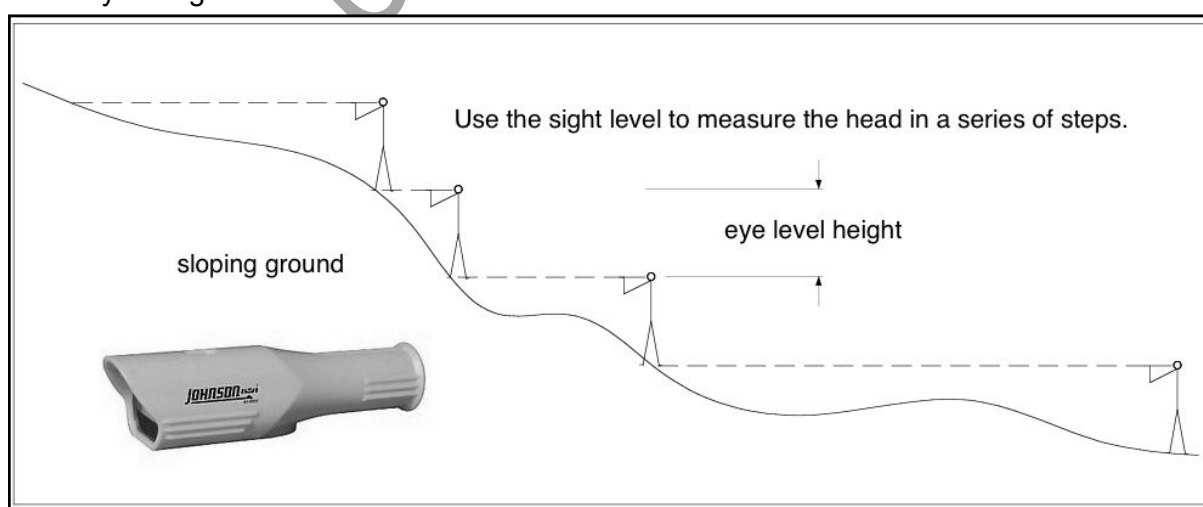

We tend to express the head in metres (or feet) but it's easy to convert between metres and PSI and Bar using conversion tables. Pressure is pressure, and it's necessary to get a number for this before you can start to plan your PowerSpout system.

1.2. What is Flow?

You will need a flow of water through your turbine and this is the other vital number to find out. Whereas head is a fixed number, flow is a moving target depending on rainfall etc, so an accurate figure is not needed but you will need a good sense of the range of flow and how often it will dry up to avoid disappointment.

If the flow is small (say 2 litres/sec) then you can divert it to fill a bucket and measure by timing how long this takes. For larger flows you may need to set up a notched weir and measure the depth of water over it. There are many techniques. See HomePower magazine for useful articles on the subject (please note that Homepower recently ceased publishing due to falling sales) :

- [Home power 170 designing a micro hydro system](#)
- [Home power 146 Micro hydro Myths & Misconceptions](#)
- [Home power 146 Pro advice for hydro end users](#)
- [Home power 104 Intro to hydro power – measurement of head and flow](#)

You can make a temporary "V notch weir" from plywood (with 90 degree notch in it as shown right) and observe the depth of water in the pool behind the weir. A scale fixed onto a post in the middle of the pond is very useful for observing the level on a daily or weekly basis.



h (cm)	Flow l/s
12	7
13	9
14	10
15	12
16	14
17	17
18	19
19	22
20	25
21	28
22	32
23	36
24	40
25	44
26	48

This table gives the flow in litres per second for various depths of water in cm. The depth is measured from the bottom of the V. Measure from the level in the pool behind, and not the level over the lip of the notch.

Even studying the catchment area upstream and the rainfall records can be a very useful approach and there are commercial software packages to help with that. Here is a theoretical curve prepared by a UK consulting service showing what % of the time the flow can be expected to exceed any given level for a particular site for example. One cubic metre, m³ is 1,000 litres of water so 0.001 is a litre.

A PowerSpout turbine can operate over a range of flows, but you may have to close a valve or two in dry periods so as to make sure that the intake is always overflowing to some degree. If air enters the penstock, your turbine power output will drop.

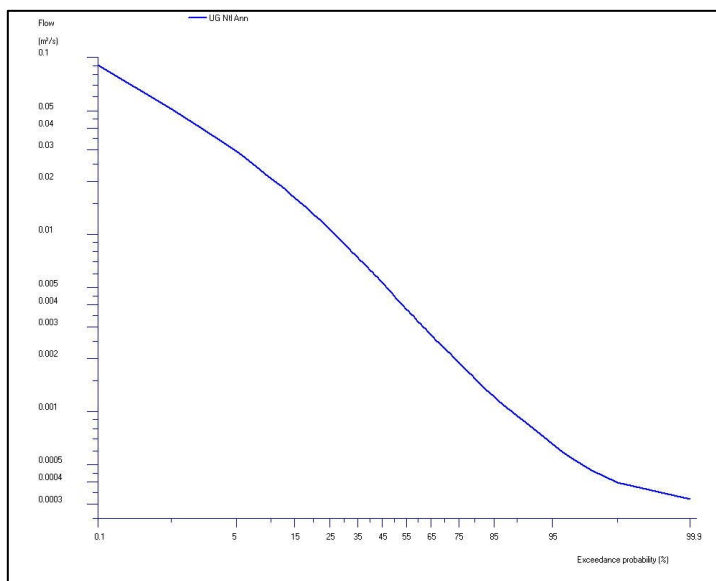

1.3. Which PowerSpout should I choose?

Selecting a suitable PowerSpout is largely a matter of knowing the head and flow, since they are designed to work at different heads. The power you will get depends directly on the head times the flow (the product of head and flow), which means that sites with high head can work with low flows, whereas the low head sites need a great deal of water per second to be useful. The three versions are shown in photos on the first page of this document.

Version	Head (metres)	Flow (litres/second)
PowerSpout PLT (Pelton)	3 – 130	0.1 - 10
PowerSpout TRG (Turgo)	2 – 30	8 - 15
PowerSpout LH (Low Head)	1 – 5	14 - 55
PowerSpout LH - mini	1 – 5	14 - 32

The Turgo is good for medium head sites and it can work with low flows, but if the flow is never more than 8 litres/second then the Pelton is a better choice because it is more efficient, runs slower and more quietly.

For more information on the LH, see the **PS LH Install manual** in our [Index](#). Note that there is now a smaller model, the LH-mini for lower flow sites.

1.4. What if I actually need a pump rather than a power source?

The Powerspout PHP is a much better option than the traditional ram pump. It is quiet, much simpler to install and can lift water to very high heads (up to 200m)

Please note that this PHP product is being phased out, as our new [SHP-TX](#) (solar water pump) has in effect displaced the need for the PHP.

You need to look at these documents (see the [Index](#) document for download links)

- [PS PHP Calculator Manual](#)
- [PS PHP Install Manual](#)
- [PS PHP Service Manual](#)
- [PS PHP Advantages Document](#)

Version	Head (metres)	Flow (litres/second)
PowerSpout PHP (Pelton Hydraulic Pump)	2-12 metres	2-10 l/sec

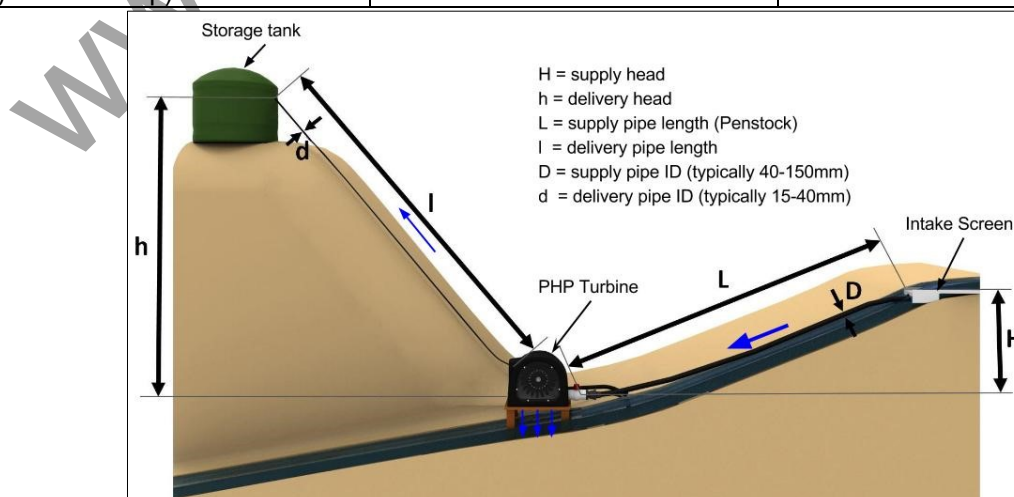

1.5. Can I run a turbine off a pump to make power?

Technically yes, you can use a pump to create a head of pressure and push a flow of water through a turbine. We do this sometimes to test our turbines. Is it a useful source of power? No it cannot be, because **you will need more power to drive the pump** than you will get from the turbine. Energy can be *converted* but there is no free lunch. It has to come from somewhere and the process of conversion is never 100% efficient so you always lose some in the process. The power used to drive the pump will always be more than the power you can get from the turbine. [YouTube videos](#) that claim otherwise are a hoax/scam. [Watch this](#) for a YouTube video that tries to correct such nonsense.

1.6. Can I run a turbine off my pool pump to reduce my power bill?

No, the pump has a job to do and any more load on the pipe work will increase the power to drive the water pump, this increases the power demand which will be more power than the turbine will generate.

1.7. Why not pump water up a hill, and run a turbine as it comes down?

Again it will take more energy to get the water up the hill than you will get back in the turbine. Again this is not 100% efficient so you will lose some energy. You might think this would be a better way to store energy than a battery. Use solar power to pump it up during the day and then run on hydro power at night? Yes it would work, but if you do this with domestic-scale pumps and turbines the losses will be so high that you will get less than 1/3rd of the energy back. A battery is much more efficient for small scale storage. It is sometimes done on a very large scale using off-peak power from [surplus generation](#)

1.8. Can I use water from my tap? It comes out at very high pressure.

There is some energy in the water coming out of your tap but not as much as you probably think. Hydro turbines use a lot of water. A household might use 200 tons of water per year. This does seem like a lot but it works out at 1/10 of a gallon per minute or about 1/150 of a litre per second. Suppose it comes in a 5 Bar pressure (72 PSI) you would be generating less than 2 watts of power on average. Yes you could produce somewhat higher power at times, but bear in mind that the pressure would diminish sharply, and actually fall to zero when you open the supply up to maximum flow.

1.9. When it rains there is a good flow from my roof. Could that run a PowerSpout?

Again unfortunately when you run the numbers there is not enough water from the roof of a building to make any sort of impact on its electricity needs. If you live in Bangladesh then 3 metres of rain might fall on your roof in one year, which adds up to 3000 tons on a 1000 square metre building. Say the roof is 10 metres above ground level your *average* power generation would be only 5 Watt from this huge building.

1.10. Can I use a large river to power my home?

It's not enough to simply have a large flow of water. Unfortunately you need both flow and pressure (vertical fall) of water. If your river is flowing fast then there might be some scope for putting an underwater current turbine into it and generating a small amount of power but we do not sell such products as there are few suitable sites (with high speed flow) near to where people live. PowerSpout products require a flow of water that can be diverted into a pipe or channel and then **fall at least 1 metres in height** before returning it to the original course.

1.11. Who should actually consider buying a PowerSpout?

Not everyone has access to large amounts of water that descend in height over their property, so most people will not be able to use a PowerSpout, but there are a huge number of sites where one or other of the various turbine types will work well, delivering cost-effective power, whether on or off the utility grid. Homepower magazine is a good source of practical information. Here is a good article on [how to avoid misconceptions](#) about what you can do with microhydro.

2. What can PowerSpout do for me?

To understand the value of a PowerSpout turbine it is helpful to start with some idea of how much electricity you need or want. Here is a chart of typical domestic usage worldwide:

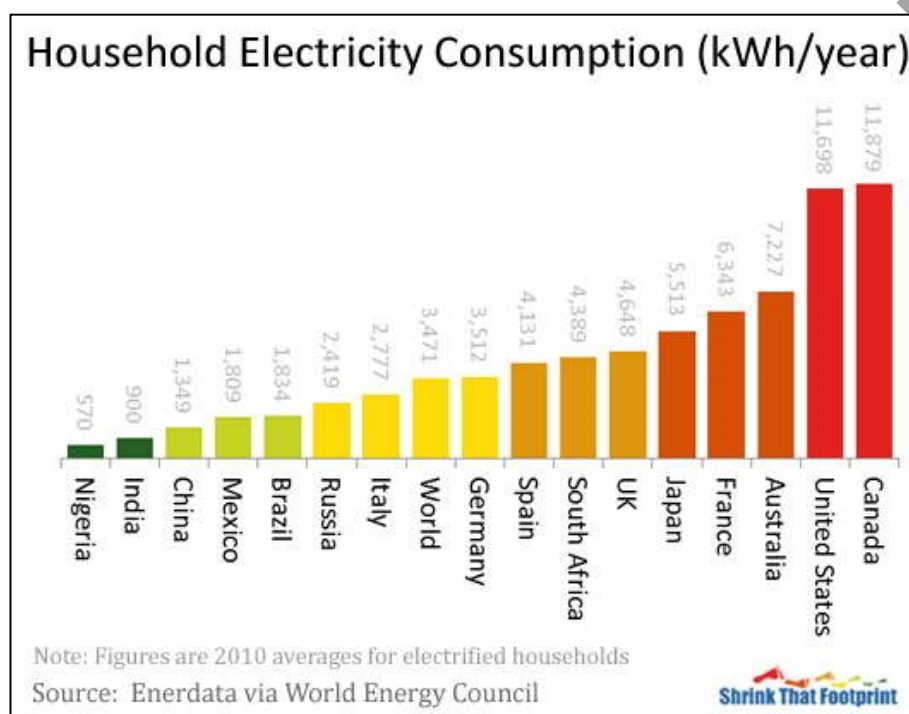

Note that the electricity is not measured in kW, as most people would assume. It is measured in kWh units per year. This is how you pay your electricity bill, and it represents your average usage in a concise way.

2.1. How much electricity will a PowerSpout provide?

As a rough guide, the kWh/year = Flow x Head x 37

For example, if your flow is 10 litres/second and Head is 10 metres, you can expect about 3,700 kWh/year (given constant flow), similar to what a German household would use.

There are operating ranges for the different products, so the following table may be more useful although bear in mind that it uses selective examples to keep it concise. Often it's a good idea to use multiple turbines where the flow permits extra power opportunities.

Estimated Annual production in kWh per year							
	1 l/s	2 l/s	4 l/s	8 l/s	16 l/s	32 l/s	64 l/s
2 m				450		2500	
4 m		200	500	1200	2300	5000	8700
8 m	200	500	1200	2400	5300		
16 m	500	1200	2400	4500	10000		
32 m	1200	2400	5000	8500	15000		
64 m	2400	5000					
128 m	5000	10600					
	Pelton			Turgo		Low Head LH	

3. What else will I need?

3.1. Do I need to build a dam?

You will need an intake structure to divert flow into a pipe. You do not need to dam up a body of water, although this could be helpful in allowing silt to settle, and leaves to float off.

You only need to capture most of the water and filter it. It may be best to leave some flow in the watercourse during dry periods so that local life forms can survive. You can find more advice about intakes in our [Intake guide](#) and our [Coanda intake manual](#).



3.2. How big does the pipe need to be?

You will need a pipe that can carry the required flow of water without consuming more than a small fraction of the pressure head in doing so. At first all that you need to know is the **length of the pipe**, and after that we can help you work out the size it needs to be. See our [Site assessment guide](#). This pipe is known as a "penstock". The pipe can be a major cost on sites where the slope is gradual and the penstock is therefore long.

3.3. Can I run my house directly from the PowerSpout?

Although the PowerSpout may be able to provide more than enough electrical energy to run your house, you will not be able to run the house directly. The reason is that you will want to consume high power at some times and low power at others, whereas the PowerSpout will deliver power at a constant rate. A PowerSpout can be used for electric heating with constant load, but for normal electricity supply there are two options:

On grid houses will need a "Grid Tied Inverter" (GTI) as used in a solar PV system. This will inject your hydro power into the domestic supply, reducing your bills. We have published several guides with titles in the format **PS GTI** to help you or your installer to choose and install these inverters. For example the Ginlong Solis inverters have been found to work well with PowerSpout turbines.

Off grid houses will need a [battery](#) to store the energy, and use an [inverter](#) to create AC power for you to use. Often there will also be solar PV panels charging these batteries (for dry spells) and a generator for backup. See our [Charge controller guide](#) and [System wiring guide](#) for much fuller discussion of the electrical system, wiring and controls. You will also find the [case studies in our Index](#) very helpful.

We recommend using a Midnite Classic charge controller between your PowerSpout and your battery system. The [Midnite Classic Guide](#) is available to help you and your installer to use this clever box of tricks. If you prefer a different make of controller then check for a **PS MPPT ... Guide** among our free pdf documents. Note that [Victron now offer a 250V controller](#) that is ideal for 48V battery charging with a PowerSpout.

When the battery is full you will need to dispose of the surplus power safely and usefully. Please see our [Diversion loads guide](#) for more help with this. Often a hydro turbine can provide ample hot water as a spin-off. If you do not have surplus energy then you probably are not charging your battery properly and it will not last long in service.

3.4. Can I use Powerspout parts and build my own turbine to my own design?

The parts from our turbines are ideal for DIY projects but beware of 'reinventing the wheel'. Making your hydro turbine is not that hard, but making it work really well to get the most Watts possible, be reliable, be safe and compliant with regulations is no minor task and can take several years work to perfect. Have a go by all means, but it may be more cost effective in the long run just to buy one and instead put your efforts into making a top quality compliant *installation*, so that the whole system will be an asset for your home into the future. It is no fun living on a slice of paradise if your family has left because the power system is meagre and unreliable.

Links to our free DIY documentation are listed below:

- [DIY smart drive applications \(generation\)](#)
- [DIY smart drive applications \(motor\)](#)
- [Older smart drive information \(generation\)](#)

EcolInnovation offer [consultancy services](#) to homebuilders developing their own designs. But we do not offer warranty on parts we sell for these projects, as they are classed as R&D.

We have observed many DIY turbines only live as long as their maker. Once this person moves on, the next owner is forced to put in a reliable, more efficient well proven solution with both manufacturer and dealer support, and spares.

4. How much will it cost?

Prices for turbines (including options which are often in drop down menus) are easily found at the [online shop](#). A PowerSpout turbine cost starts from about US\$ 1,600. Spare parts and installation accessories are also available for if bought alongside the turbine. The whole system with pipes, cables, inverters, labour etc will cost a lot more, but you will need to design it before you can estimate the total. The dealer network is there to help you assess feasibility, and to offer you the other equipment and expertise.

All global dealers are listed on our [website](#). **Gold dealers** are the most experienced and will ship drop to almost all global destinations. We encourage all customers to locate a dealer who knows the local situation e.g. product and service suppliers and local regulations. EcolInnovation, the manufacturer of PowerSpout, will only be your dealer if you cannot find anyone serving your region.

Please note:

- Dealers want to help you find an appropriate solution, to do this efficiently you must promptly supply all information requested.
- All dealers should offer similar retail pricing for PowerSpout turbines, although price differences may lie in other 'system' components, local taxes, margins and freight costs.
- There is often a benefit from using your closest dealer to facilitate support (advice, installation, maintenance, replacements etc).
- Negotiating with several dealers at once is unlikely to achieve a cost reduction but will take up lots of time and energy (buyer/dealer).
- EcolInnovation encourages mutual respect and honest transactions as part of a more open and sustainable world.
- All PowerSpout turbines are sent fully assembled. Only the jets are removed for packing. LH turbines may have the Smart Drive removed.

5. How do I buy one?

Before placing an order all customers must **obtain good site data** to ensure that the most suitable type of PowerSpout is selected, and the turbine(s) of your choice are optimised for your conditions.

Please follow this simple process to avoid frustration or disappointment.

1. Make sure you have a viable supply of **naturally falling water**
2. Select a dealer to work with
3. Submit complete site data (see next section) to your dealer
4. Pay promptly
5. Enjoy using low impact renewable energy
6. Send us your feedback and an install picture
7. Keep careful notes of performance and maintenance in the [PS Maintenance Log](#)

5.1. What site data do I need and how do I use it?

In order to assess your hydro site potential you need to measure the following properties:

- Head
- Flow
- Pipe length
- Cable length

You can use the data to assess your hydro site potential in the following ways:

- Investigate the most suitable turbine type (see above)
- Assess options and power output using the online Advanced Calculator tools <http://www.powerspout.com/calculators/> Read the manual [PS all Calculator Manual](#)
- If you are unable to use the Advanced Calculator tools then complete the Table in Section 8 below so your dealer can advise you of the best solution to meet your needs.

When using the Advanced Calculator you will notice that there is no mention of kWh/year. Output will be expressed in Watts. Keep in mind that 500 Watts output is equivalent to 4,380 kWh/year. This may surprise a lot of readers, but continuous power at what seems a low level will actually add up to a substantial contribution to your household needs, and in many cases will exceed your needs.

When you are ready to purchase a PowerSpout, you must share your site data with your selected dealer. There is a 'Save and Share' function at the end of the Advanced Calculator to allow you to do this easily. No hydro turbine orders will be accepted until all site data is supplied.

Your turbine will be designed for the site data supplied. Often the reality turns out different from the measurement. If you operate your turbine on a site with different head or pipe size for example, the output power will differ and not necessarily match the prediction of the Advanced Calculator. A new generator core may be required to obtain the best results in such cases. If you intend to run your turbine over a wide range of flow rates, you need to state this at the time of ordering. A different additional generator core may be needed in some cases, and this can be supplied for an additional charge.

5.2. Demand side data

It is always helpful if you can advise how much power you are likely to need at your site in kWhrs/day, as your hydro resource may be able to generate more or less than is required.

6. Placing the order

Your dealer will

- Help you assess your site (if requested via email)
- Place the order with EcoInnovation by submitting data from the Advanced Calculator
- Advise you of delivered costs of the turbine, including relevant local charges e.g. taxes and duties
- Arrange for the turbine to be delivered to the appropriate destination
- Provide a target date for the delivery of your turbine

Your dealer is also able to advise on and/or supply

- Appropriate energy system design and components
- Technical expertise to meet local regulations

6.1. Important notes

Freight charges on additional items can often be avoided if ordered at the same time as the turbine. Please refer to our online [freight tips](#).

If buying direct from EcoInnovation note that the price charged **excludes** any import duty and taxes that the purchaser will have to pay on entry into their country. To determine what this tax/duty may be, contact your own customs for advice. Please note some countries exempt renewable energy products from GST/VAT and import duty, but many do not.

PowerSpout products have been subjected to testing under international Standards and have passed Impact and Drop Tests. These provide confidence that PowerSpout turbines in standard packaging can withstand considerable transport and handling abuse such as being dropped from a height of 1m onto a hard floor.

Please note that our turbines are packed for only one airfreight movement to the address given. If you intend to move the turbine(s) by road you must 1st check for any transit damage and repack the goods suitable for the terrain that you are transporting the goods over.

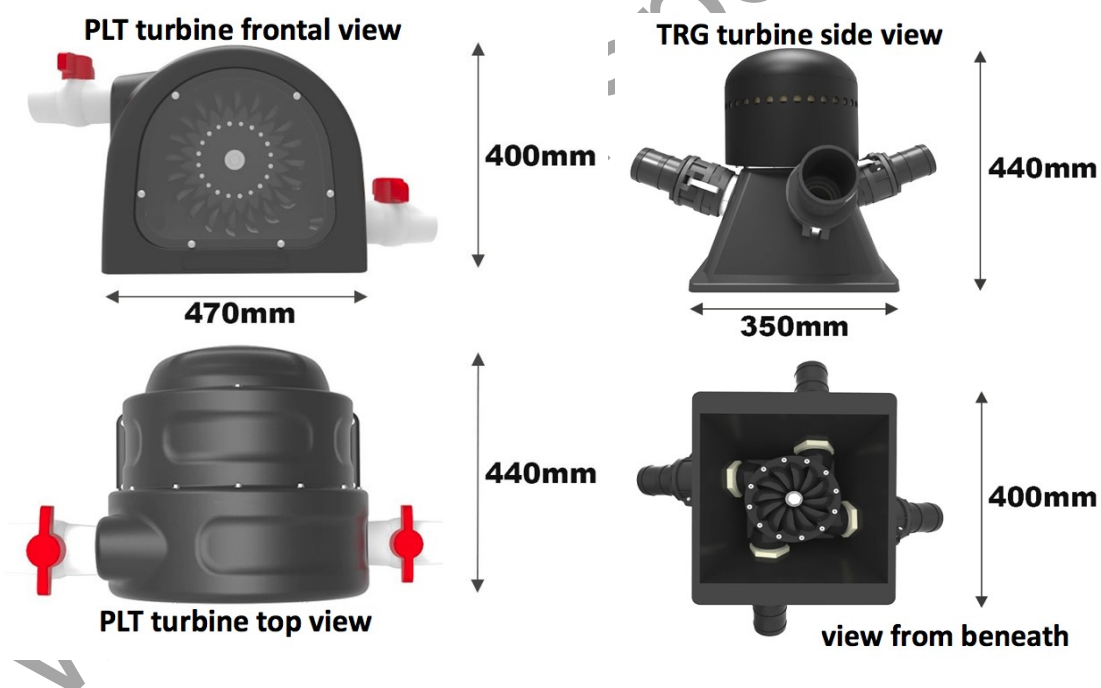

7. Product range

See photos on title page of this document. Each of the PowerSpout versions described earlier has a number of specific models made for your site to work at different voltages. You would for example order a PLT80 for operation at 80 volts along with a Midnite Classic 250 controller. Be aware that these models' voltage will only be applicable to your site **if you have given us the correct site data**.

In most cases, the operating voltage will be much less than the maximum open circuit voltage (Voc). If you wish to operate at a higher voltage whilst limiting Voc then you can add our PowerClamp unit to protect against excessive voltage. See the [PowerClamp Install Guide](#) for an explanation of this option and why it might be useful to you. In most cases you will not need a PowerClamp.

Common versions of PowerSpout PLT (see [PLT manual](#))

	Off-grid					On-grid	
PLT model	14	28	40	56	80	170	200
Max cable length m	50	150	250	500	1000	1000	1000
Operating cable V	14	28	40	56	80	170	200
Max open circuit V	38	75 ELV US/EU	120 ELV NZ/AUS	150	220	<450	<550
Regulator/inverter	PWM	PWM	MPPT	PWM	MPPT	Grid-tie	Grid-tie
Battery voltage	12	24	12/24	48	12 - 48	n/a	n/a

Common versions of PowerSpout TRG (see [TRG manual](#))

	Off-grid				On-grid	
TRG model	28	40	56	80	170	200
Max cable length m	150	250	500	1000	1000	1000
Operating cable V	28	40	56	80	170	200
Max open circuit V	75 ELV US/EU	120 ELV NZ/AUS	150	220	<450	<550
Regulator/inverter	PWM	MPPT	PWM	MPPT	Grid-tie	Grid-tie
Battery voltage	24	12,24	48	12 - 48	n/a	n/a

Common PowerSpout LH and LH Pro products (see [LH manual](#))

All LH and LH Pro products connect via MPPT regulators or grid-tied inverters. The voltage numbers for LH models refer to the Maximum voltage or Voc rather than the operating voltage, which will be about half of this maximum.

- **LH150, LH150Pro and LH150-mini** – use with MPPT regulator rated for up to 150 VDC charging 12/24 VDC batteries. Cable voltage may be as low as 50 VDC.
- **LH250, LH250Pro and LH250-mini** – use with MPPT regulator rated for up to 250 VDC charging 12/24/48 VDC batteries. Cable voltage may be as low as 80 VDC.
- **LH400, LH400Pro and LH400-mini** – use with MPPT regulator or grid connect inverter rated for up to 400 VDC. Cable voltage may be as low as 140 VDC.

8. Data required for PowerSpout manufacture

If you have already completed the [online calculation](#) and sent the file to your dealer then you do not need to complete this table.

You must advise your dealer the make and model of the MPPT regulator or grid connect inverter you intend to use and how many kWhrs you need to meet your daily power needs.

Hydro site data required for PowerSpout turbine manufacture

Question	Units
PowerSpout turbine type	PLT, TRG, LH, LH Pro or LH-mini
Have you read the PowerSpout product manuals? You must do so before placing an order	Yes/No
Head at site (vertical drop/fall of pipe)	m or ft
Pipe or flume length required to get fall	m or ft
Supply pipe inside diameter if installed	mm or inch
Do you want us to advise your pipe size?	Yes / No -
Flow available at intake	l/sec or gal/min
What is the cable length from turbine to the power shed?	m or ft
If cable is installed, what size is it?	mm ² or sq inches
Do you want us to advise cable size?	Yes / No -
For MPPT applications state your battery voltage	12/24/48 Volts
For MPPT applications state the regulator make and model	
For Grid connect applications state the inverter make and model you intend to use	
How much power do you required at your site on average	kWhrs/day

Additional Hydro site data required for PowerSpout LH, LH-mini or LH Pro manufacture

Questions	Units
Can a vertical draft tube be installed?	Yes / No
Can you buy 200mm and 250mm OD thin-walled PVC pipes locally to make the draft tube?	Yes / No
If No above then state the inside and outside dimensions of the PVC pipes you can obtain of a similar size. State these dimensions for both the plain and flared ends on the pipe. (read LH Installation manual for more information)	Flared end ID ____ mm or Inch Flared end OD ____ mm or Inch Plain end ID ____ mm or Inch Plain end OD ____ mm or Inch